

1 Top

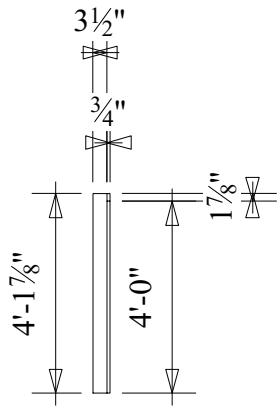

2 Left

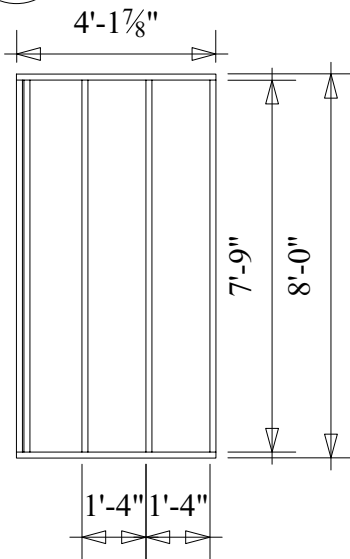

3 Front



4 Right

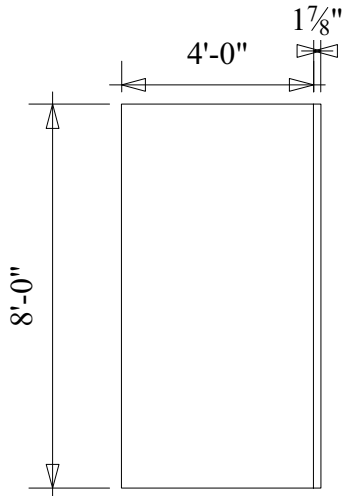

5 Right Iso
3/16" = 1'-0"



6 Left Iso
3/16" = 1'-0"

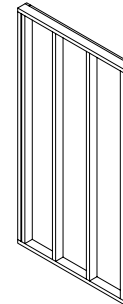

General Notes

- Build.: (2) For Support Wall/Wagon Level
 Cut List. 2x4 Lumber:
 (2) 4'-1-7/8"
 (5) 7'-9"
 3/4" Plywood:
 (1) 4'x8'
 (1) 1-7/8"x8'
- Instructions. -Cut Lumber
 -Screw cut 2x boards with (3) 3" screws at each intersection.
 -Screw 3/4" Plywood with 1" screws every 6" and hitting each corner/toggle.
 Build Support Wall D with Mirrored Facing (3/4" Ply) Compared to Picture

Show Name Noises Off 2019		
Reference 1/4"=1'	Drawn By Scott Bedell	Date 09/04/19
CAD File Name Support Wall C and D		